

# Piped services order form

**EXCEL**  
LONDON
Valid from events 1<sup>st</sup> January - 31<sup>st</sup> December 2023

Update 05.01.23

**Advanced rates** Valid up to 28 days prior to the first day of tenancy.**Standard rates** Valid within 28 to 7 days prior to the first day of tenancy.**Onsite rates** Valid within 7 days prior to the first day of tenancy, availability confirmed on request.**Please note that orders will not be fulfilled until payment is received in full. Please note that all orders are subject to availability.**
**Click here to order these services on our Webshop**

 Rigging • Stand cleaning • Waste removal • Internet • Audiovisual  
and other essentials for your stand

Payments by Visa and Mastercard only.



## Water & waste

0.5" water pipe supply &amp; connection

1.5" waste pipe supply &amp; connection

0.5" water pipe and 1.5" waste pipe supply &amp; connection to one item

0.5" water pipe and 1.5" waste pipe supply &amp; connection to client's own single sink (no heater)

 0.5" water pipe and 1.5" waste pipe supply & connection to client's own  
double sink (no heater)

 0.5" water pipe and 1.5" waste pipe supply & connection to client's own single sink  
and water heater

 0.5" water pipe and 1.5" waste pipe supply & connection to client's own double sink  
and water heater

### Single sink package

Includes sink, heater, water and waste supply and connection.

**Power not included. Please order through the event electrical contractor.**

Single sink dimensions L 1000mm x W 700mm x H 950mm

### Double sink package

Includes sink, heater, water and waste supply and connection.

**Power not included. Please order through the event electrical contractor.**

Double sink dimensions L 1400mm x W 700mm x H 950mm

## Equipment hire

**Hire of over sink water heater** (heater hire only - please note this does not include water or  
waste connections, tee offs or any electrical connection or supplies)

**Hire of under sink water heater and vented taps** (heater and tap hire only - please note this  
does not include water or waste connections, tee offs or any electrical connection or supplies)

**Domestic dishwasher hire - supplied with tablets and hoses** (appliance hire only - please  
note this does not include water or waste connections, tee offs, water heaters or any  
electrical connection supplies)

## Additional options

Water tee-off to one appliance on same floor level - maximum distance 1.5m from water supply

Waste tee-off to one appliance on same floor level - maximum distance 1.5m from water supply

Additional cost of each service when installed on the upper floor of a stand  
(two appliances maximum allowed on upper floors)

	Advanced rate	Standard rate	Onsite rate
QTY		QTY	
	£460	£552	£662
	£460	£552	£662
	£874	£1,048	£1,258
	£874	£1,048	£1,258
	£913	£1,095	£1,315
	£963	£1,155	£1,387
	£1,014	£1,217	£1,460
	£1,126	£1,351	£1,621
	£1,170	£1,405	£1,685
	£118	£142	£171
	£236	£283	£340
	£174	£209	£250
	£152	£183	£219
	£152	£183	£219
	£213	£256	£307

## Water pools, barriers & tanks

Costs quoted are for filling and emptying.

Per 1 litre / 1m<sup>2</sup> / 0.22 imperial gallon / 0.264 US gallon

QTY	Advanced rate	QTY	Standard rate	Onsite rate
	POA		POA	POA

## Compressed air

Compressed air supplies are installed to the stand only.

Final connections to any stand equipment must be carried out by the client's own competent installers.

Compressed air with standard 3/4" isolating valve

	£840		£1,008	£1,210
	£863		£1,035	£1,243

Compressed air with standard 3/4" isolating valve and 1/2" reducer

The compressed air is supplied through a flexible hose and can be terminated with either a 3/4" BSP isolating valve, a 3/4" BSP isolating valve with 1/2" or a 1" BSP isolating valve. The compressed air supply is maintained at a pressure between 5 and 6 bar (75-90 psi) subject to normal control fluctuation. The maximum capacity of a supply is 6 litres per second (80 cubic feet per minute) of free air. The compressed air supply is of industrial quality containing normal levels of contamination from oil, water and particulate matter. Users requiring pure compressed air must supply their own filtering, drying and regulating equipment to obtain the quality required.

## Gas

All gas supplies are installed to the stand only. Final connections to equipment must be carried out by your own competent installers.

The competent person employed by the stand holder must be Gas Safe registered and must provide evidence of this to the venue installation teams before work commences.

Natural gas 1" BSP internal thread isolating valve

	£924		£1,109	£1,331
--	------	--	--------	--------

The gas supply is through a flexible hose and terminated with a 1" BSP internal thread isolating valve. Natural gas is supplied at a pressure of 22mm Hg or 12" Wg with a flow rate of 2.5 L/s or 300 c.f.h. Any person carrying out work involving the installation, maintenance or checking of gas appliances (or associated fittings) must be competent under the Gas Safety (Installation and Use) regulations 1998.

## Additional labour

Piped services technician labour (per day)

	£150		£180	£216
--	------	--	------	------

SUB TOTAL  
(excluding VAT)

£
---

20% VAT

£
---

TOTAL  
(including VAT)

£
---

## Service position

Please supply a plan (example below) specifying the location of the service.

**Please note that you are liable for a full recharge of the item ordered if the location is submitted incorrect.**

Please tick if you have platform recommended size of 100mm. If you do not have a 100mm platform we cannot guarantee that the event health and safety team will allow the connection of your appliances as there may be trailing pipes that could constitute a hazard.

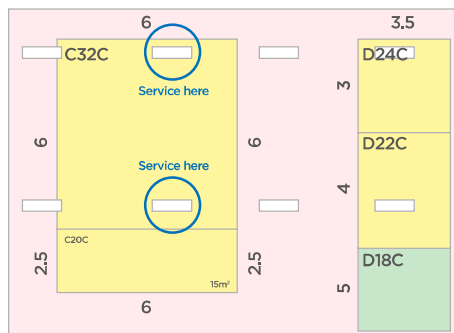

### Key requirements

1. Circle or mark the location of the ordered service.
2. Ensure neighbouring stands are marked on the plan, so the orientation is clear.

## Summary of terms

- Please note that you are liable for a full recharge of the item ordered if the location submitted is incorrect.
- ExCeL London reserves the right to adjust pricing for any service during 2023. Subject to payment being received by ExCeL London in respect of the service within 28 days of the date of the order confirmation, the price quoted on the order confirmation for that service will be honoured.

## Cancellation policy

If the exhibitor or their representative notifies the Exhibitor Services Team of their order cancellation:

- 28 days or more prior to the first day of the event tenancy\*, a refund or credit of 100% of the order value is offered.
- 27 to 8 days prior to the first day of the event tenancy\*, a refund or credit of 50% of the order value is offered.
- Within 7 days prior to the first day of the event tenancy\*, no refund or credit will be offered.

\*If you are uncertain as to the first day of tenancy of the event please contact [exhibitororders@excel.london](mailto:exhibitororders@excel.london)

## Event details

Event title: .....

Stand Number and/or Room Name: .....

Exhibitor name: .....

Please tick if space only

## Order contact details

First name: .....

Last name: .....

Job title: .....

Company: .....

Address: .....

Country: .....

Post/zip code: .....

Telephone: .....

Email: .....

VAT ref: .....

Direct Mail Opt-in

Please tick if you are a contractor

## Invoice details

These are the details as they will appear on your invoice (this cannot be changed at a later date)

Same as order contact details:

Please complete this section if different from Order contact details.

First name: .....

Last name: .....

Job title: .....

Company: .....

Address: .....

Country: .....

Post/zip code: .....

Telephone: .....

Email: .....

VAT ref: .....

## Payment details

Payment Method:  Bank Transfer

Credit Card (*Visa and Mastercard only*)

PO reference: .....

### Important

Services will not delivered until full payment is received.

This order is accepted on the understanding that full ExCeL Event Services Terms and Conditions apply (available [here](#))

Send by email